

# Efficient powering of communication and IT equipments using rotating UPS

E. Blondel, Swisscom (Schweiz) AG; C. Monney, Swisscom (Schweiz) AG

## Abstract

Today, the demand for uninterrupted power supply for Telecommunication and Internet services increases drastically. Following the same trend, cooling demand explodes. Supplying sufficient power with extremely high reliability becomes even more challenging.

The era of telephone exchanges using 48V power supply and 8 hours of battery backup is past. Telecom Operators are currently migrating from POTS to all IP. In addition, broadband Internet access for everyone using DSL or fibre is already reality. More and more applications like TV on demand, streaming services, online gaming or entertainment are very power hungry.

For such large systems, static UPS systems are no more efficient. A better alternative is offered by rotating UPS, also known as “No-break”. In addition to requiring less space and no batteries, these systems have a better power efficiency too.

## 1 Motivation

To overcome the energy demand for IT applications, Swisscom has yet installed 2 No-break systems: the first one consists in two 1 MVA systems put in parallel (1+1 configuration) and the second one consists in a parallel redundant 4(6) x 720kVA installation. Till now, no power outage has been registered. During the design phase, the main challenge is to integrate the system in an existing building, thus using existing exhaust pipes and ventilation channels and dealing with noise and vibrations. Since the beginning, the effectiveness of these no-break systems has been registered by power quality analysers. Until now, no “out of tolerance”-event has been registered.

## 2 Benefits of rotating UPS

Traditional UPS systems with Genset consist in

- Genset and alternator
- Switchgears and command panels
- UPS
- Batteries
- Distribution

With rotating UPS only a rotating energy storage module needs to be added between the Genset and the alternator. This configuration reduces the place needed for batteries and static UPS [8]. In addition, this is an envi-

ronmentally friendly solution as no poisonous products are stored.

Large static UPS systems require also large batteries. The batteries' rooms have to be separated from the rest of the equipment to ensure the required redundancy in case of failure. Ventilation of the UPS and of the battery room must be also provided.

Let us consider the case of 3+1 720kVA system:

- The realization with static UPS requires, for 20 minutes autonomy, the following: 5 UPS each 300kVA in parallel and 1200Ah / 400V Battery (e.g. 5 x 240 Ah or 10 x 120 Ah).
- The realization with rotating UPS requires only an additional energy storage module, which makes the Generator set about 2m longer. A separation choke must be also added.

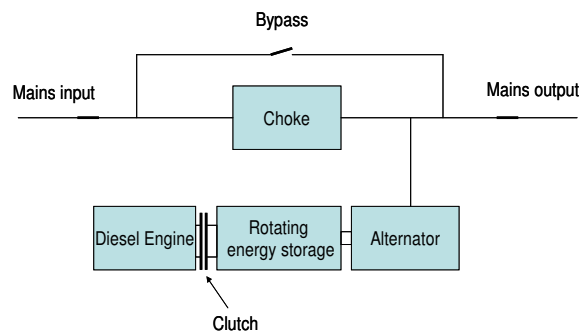

Figure 1 General schematic diagram of a rotating UPS



**Figure 2** Genset 720kVA / 640 kW with rotating energy storage

### 3 Disadvantages

A rotary UPS unit need usually larger place in the Generator room and is also heavier. It also produces constantly audible noise. In addition, a rotary unit requires routine maintenance. For example, you must stop it for controls and inspections, replace bearings periodically. Bearing failure is predictable with routine testing for deterioration. In our systems we installed vibration sensors that provides remote alarm in case of increasing of the vibration of the whole rotating system

### 4 Difficulties

For 3 years, all uninterruptible power supplies installed in our telephone exchanges or data centres were based on static converters. This is why little technical know-how and no practical experience about no-break systems were available internally. Though this system seems quite simple at first look, lot of effort was put in understanding how it works, especially in transient phases.

In order to deeper understand the principle of rotating UPS, we have performed Factory Acceptance Tests (FAT) in the manufacturer's facilities. Different situations such as load steps, mains failure, mains return, mains failure without starter battery, or faults in the control panel have been verified. In addition, experience has shown that additional tests were required: short circuits, measurement of the current of the starter battery, load step 100%, bearing vibrations and acoustic noise.

Finally, we have installed an energy analyser on each output of the first installed system (1+1) in order to verify the good functioning and gain more experience.

## 5 Experience

The experience with 2 systems over 3 years exceeds our expectations. Until end of 2008, no power outages or major fault have been registered. Nevertheless, 2 minor events have occurred: the first one consists in a short circuit in the MV substation when the second one is due to the partial failure of a bearing about 2 weeks after the start-up of the system. This last was detected by the supervision system of the machine and could be solved without any interruptions.

Both examples show the limits of the rotating system. The short circuit case will be studied deeper in the next chapters.

## 6 EMC

Experience gained over 15 years [1]; [2] has shown that large static UPS produce lot of conducted disturbances.

There is a discrepancy between standards for telecom equipment (ETSI EN 300 386 [3], CISPR 22 [5]) and for UPS (IEC 62040-2 [4]). ETSI EN 300 386 [3] has to be applied for Telco equipment and CISPR 22 for IT equipment. Due to the convergence to an all IP network, the immunity standard for the equipment will be based on CISPR 24 [6].

Let consider the conducted emission's case: large UPS rated over 400A output current may have conducted emissions higher than the minimum immunity required for Telco equipment.

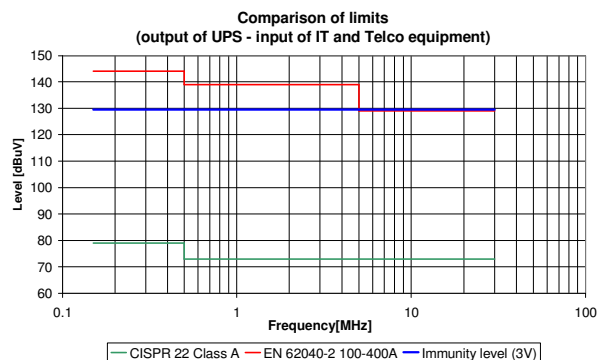

**Figure 3** Comparison of limits static UPS vs. IT equipment

This discrepancy may lead to performance problems in the IT equipment. This is due to the power electronics components of the mains rectifier and inverter. The experience shows that most disturbances are issued from the UPS in-

verter. The commutations' spikes generate broadband disturbances.

The power processing of rotating UPS doesn't imply any power electronics. The scheme and components are simple; the EMC emissions are limited to the rectifier bridge of the alternator and the rectifier bridge of the magnetic brake of the rotating energy storage mass. These two circuits are electrically isolated from the mains and the influence remains negligible. In addition, the mains choke will block the disturbances coming from the mains. It has to be noted that this is not an EMC choke, but it acts in the frequency range below 1 MHz.

## 7 Short circuits, dips and fault conditions

The weakest point of the rotating UPS is the transfer to the output of mains outages. Let consider 2 cases: the first one is an outage due to the opening of the input mains circuit breaker and the second one is a short circuit on the medium voltage path.

In the first case, we only have to consider the interruption of the energy flow to the connected load. Thanks to the stored energy in the rotating mass, no mains deviation of the frequency and the voltage can be observed.

In the second case, the rotating UPS will provide energy to the load and, at the same time, to the short circuit. The amount of energy supplied to the short circuit is huge and can be found in figure 5. The explanation of this phenomenon is based on figure 4 and given here after.

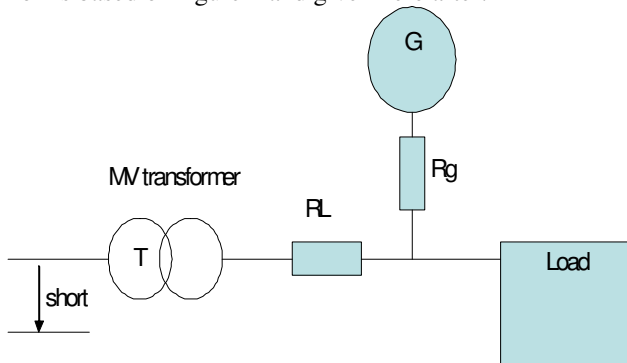

Figure 4 Schematic of the short-circuit situation

During the short circuit on the medium voltage and before that the mains circuit breaker opens, the load voltage will drop to following value:

$$U_{load} = U_g \times \frac{R_L + R_{tr}}{R_g + R_L + R_{tr}}$$

Where:

$U_{load}$  = voltage across the load

$U_g$  = Generator voltage at no load (open circuit)

$R_g$  = copper resistance of the generator

$R_L$  = copper resistance of the choke

$R_{tr}$  = secondary copper resistance of the MV transformer

At the same time, the generator current will be the following:

$$I_g = \frac{U_g - U_{load}}{R_g}$$

Where:

$I_g$  = generator current

$U_g$  = Generator voltage at no-load

$R_g$  = copper resistance of the generator

$U_{load}$  = Load voltage during the short-circuit

The current flowing in the reverse direction in the mains is:

$$I_{ss} = I_g - I_{load}$$

Where:

$I_g$  = generator current

$I_{ss}$  = Ishort-circuit

$I_{load}$  = Load current during the short-circuit

During the short-circuit period, the load current increases because the load has a constant power characteristic. For example: when the mains voltage drops 15%, the current increases 17%.

The mains circuit breaker has to be trimmed to open in the shortest time with this current. The experience demonstrates that a short-circuit on the MV mains can produce an important voltage drop on the output of the rotating UPS. In our case a drop of 20% during 40-60 ms was observed.

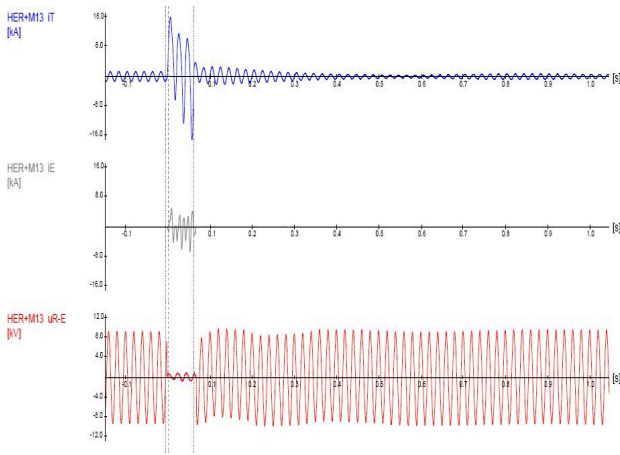

**Figure 5** Short-circuit measurement in the MV station.

The figure 5 above shows the measurement in the 20kV MV station. The short-circuit duration is about 60ms or 3 periods.

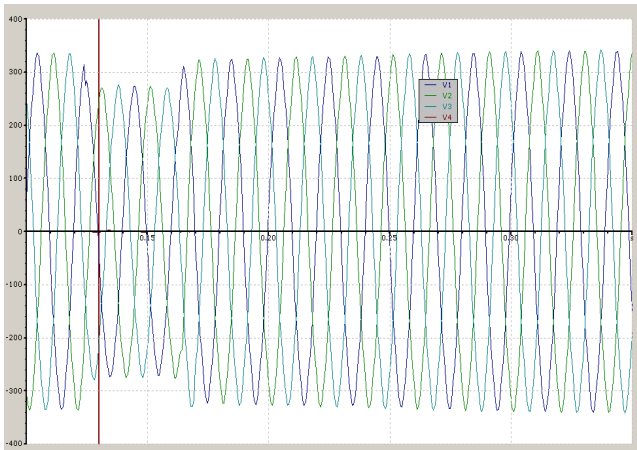

**Figure 6** Voltage drop measurement on the output of the rotating UPS.

Figure 6 presents the rotating UPS output voltage. The comparison with the CBEMA curve shows that the drop should not be critical. Nevertheless, it is important mentioning that IT equipment such as HP Blade and Dell Blade server chassis require at least 200V as input voltage. Whenever the voltage drops below 200V, it is unsure that the IT equipment will work correctly.

This can be avoided if calculations are performed, which take into account all impedances of the mains network. A good choice of the choke and the MV transformer can be realised by performing calculations with a simulation's software. It will prevent too deep and too long dips in the

case of a short circuit. As a rule, the voltage drop should be less than 15%.

## 8 Efficiency

The overall efficiency of the system varies with load and time. One important and variable parameter is the current needed for speeding up the mass in rotation. Due to the pulsation at the input of the UPS, it is hardly possible measuring with a standard power meter. The efficiency can only be estimated by using energy counter over a longer period of time. The system has constant power losses in the bearings and cooling system. The variable part is the power loss in the choke which varies with the square of the current. At full load, the efficiency reaches 94% and, at 20% load, it is still about 81 %. The measurements are mean values on a 15 minutes period.

## 9 Costs

Cost comparison analysis has been made for static and rotating UPS. Different manufacturer of rotating UPS have been considered in the study case. Different manufacturers of static UPS have been considered also. For parallel operation of static UPS, the max output power has been fixed at 200, 250 and 300 kVA because these units are available from most of the manufacturers.

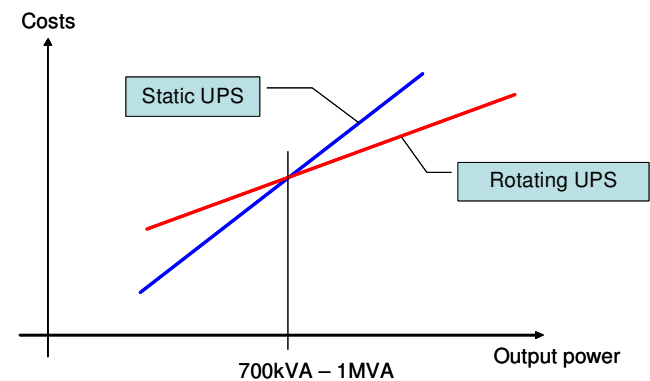

**Figure 7** Breakpoint of costs

Cost calculation is based on 15 years of operation (CAPEX and OPEX) including periodic replacement of hardware parts (maintenance). Figure 7 shows that, for an installed power greater than 1MVA, the no break solution is less expensive. Moreover, as already mentioned, this installation is more environmentally friendly due to the lack of batteries.

## 10 Conclusions

The benefits of rotating UPS have been pointed out in this paper. It makes sense for installations over a certain size, let say 1 MVA, where the costs drops under the traditional solution with static UPS. The case of short circuit on the mains input or in the MV station has been largely discussed. A lot of care should be taken for this case. For applications like large data centre and Telco applications the EMC issue should be carefully analysed. Our experience is until now positive and we are looking forward for new installations.

## 11 Literature

[1] EMC testing of physically large power supplies: conducted disturbance measurements using a substitutive method Enrico Blondel (Swisscom Ltd), Johannes Biner (Swisscom Ltd) Ostermundigenstrasse 93, 3050 Berne Switzerland Intelec 2004

[2] E. Blondel, J. Biner, EMC Course of applied EMC for UPS, Swisscom Innovations, 2002

[3] ETSI EN 300 386 Electromagnetic compatibility and Radio spectrum Matters (ERM); Telecommunication network equipment; Electromagnetic Compatibility (EMC) requirements

[4] IEC 62040-2 Uninterruptible power systems (UPS) – Part 2: Electromagnetic compatibility (EMC) requirements

[5] CISPR 22 Information technology equipment – Radio disturbance characteristics – Limits and methods of measurement

[6] CISPR 24 Information technology equipment - immunity characteristics – Limit and methods of measurement

[7] Euro-Diesel, Presentation of Nobreak KS® Dynamic UPS Systems

[8] Hitec, Presentation of Diesel Rotary UPS Systems